

DIVISION: 05 00 00—METALS
Section: 05 05 27—Metal Connectors

REPORT HOLDER:

HENRY VENABLES PRODUCTS, LTD.

EVALUATION SUBJECT:

BLIND BOLTS

1.0 EVALUATION SCOPE

Compliance with the following code:

- 2018, 2015, 2012 and 2009 *International Building Code*® (IBC)
- 2013 *Abu Dhabi International Building Code* (ADIBC)†

†The ADIBC is based on the 2009 IBC. 2009 IBC code sections referenced in this report are the same sections in the ADIBC.

Property evaluated:

Structural

2.0 USES

Blind Bolts are designed for connecting structural steel to hollow structural section (HSS) steel members and other structural steel elements where access is difficult or restricted to one side only. Blind Bolts are evaluated for resisting tension and shear loads in bearing-type connections. Blind Bolts are alternatives to bolts described in Section J3 of AISC 360, which is referenced in Section 2205.1 of the IBC, for bearing-type connections.

Blind Bolts are used to resist static loads, wind loads, and seismic loads in structures assigned to Seismic Design Categories (SDC) A through C in accordance with Section 1613.2.5 of the 2018, 2015 and 2012 IBC, and Section 1613.5.6 of the 2009 IBC.

3.0 DESCRIPTION

3.1 General:

Blind Bolts are assembled from five steel components, consisting of a slotted bolt, toggle and a flange nut with integrated washer. The steel bolt features a partially threaded shank with a smooth slotted cylindrical section and toggle. See Figure 1. Blind Bolts are available in carbon steel with zinc flake finish and stainless steel. Nominal Blind Bolt sizes include 5/16 inch (M8), 3/8 inch (M10), 1/2 inch (M12), 9/16 inch (M14), 5/8 inch (M16), 3/4 inch (M20), 1 inch (M24) and 1 3/16 inch (M30) with lengths as shown in Tables 1 and 2.

3.2 Materials:

3.2.1 Blind Bolt: Blind Bolts are manufactured from steel complying with ISO Class 10.9 carbon steel ($F_u = 1000$ N/mm² and $F_y = 900$ N/mm²), and A4-70 stainless steel ($F_u = 700$ N/mm² and $F_y = 450$ N/mm² with 0.2 percent elongation).

3.2.2 Toggle: The toggle is manufactured from steel complying with BS EN ISO 4014.

3.2.3 Flange Nut: Flange nuts comply with BS ISO EN 4032 Grade 8 and Grade 10 for carbon steel Blind Bolts and A4-70 for stainless steel Blind Bolts.

3.2.4 Finish Coating: Carbon steel Blind Bolts are non-electrolytic zinc flake coated with Geomet® 500 as described in the approved quality documentation.

4.0 DESIGN AND INSTALLATION

4.1 Design:

Blind Bolts are alternatives to bolts described in Section J3 of AISC 360, which is referenced in Section 2205.1 of the IBC, for bearing-type connections. The connection design with Blind Bolts must comply with this report, Section J3 of AISC 360 and the strength design information for the Blind Bolt provided in Tables 3 and 4 of this report. The load-carrying capacity of the connection depends on the Blind Bolts, the type of steel elements connected (such as HSSs), and their cross sections (thickness). The allowable strength is limited by the strength of the weakest component in the bolted assembly, which includes the steel elements of connection and the Blind Bolts. The capacity may be governed by the steel elements and/or connecting steel elements in the case of thin sections, or the Blind Bolt in the case of thick sections (or a combination of the two). All limit states must be checked to determine the load-carrying capacity of the connection. Combined tension and shear loading must comply with the following:

$$\left(\frac{\text{Tension Demand}}{\text{Tension Capacity}}\right)^2 + \left(\frac{\text{Shear Demand}}{\text{Shear Capacity}}\right)^2 \leq 1.0$$

4.2 Installation:

Blind Bolts must be installed in accordance with the details noted in this section, the manufacturer's installation instructions shown in Figure 2 and the approved plans.

1. Holes must be drilled into the steel sections to be connected, ensuring that the holes have the correct diameter and spacing in accordance with this report, and the correct design requirements for the connection, as indicated in the approved plans.

2. The steel elements to be connected to each other must be positioned to ensure:
 - a. That the two sections are lined up and rest one against the other without any gap. Clamps must be used as necessary to hold the two steel elements together and to prevent formation of gaps.
 - b. That the holes are aligned, using a mandrel if necessary.
3. The supplied flange nut is attached to the threaded end of the Blind Bolt and the Blind Bolt is inserted into the hole noting the position of the indicator mark on the bolt head. The orientation of the toggle and slot must be parallel to the applied shear force. The shear plane must be within the slot length.
4. Rotate the Blind Bolt 180 degrees. This action will release the toggle. Alternatively, for M16 size and larger Blind Bolts, the supplied wire tool may be utilized to release the toggle.
5. Use a flat head screwdriver to brace the Blind Bolt from rotating.
6. Tighten the flange nut with a wrench to the specified torque.

4.3 Special Inspection:

Special inspection is required in accordance with Sections 1705.1 and 1705.2 of the 2018, 2015 and 2012 IBC or Sections 1704.3 and 1704.15 of the 2009 IBC, whichever is applicable. The manufacturer must submit inspection procedures to verify proper installation of the Blind Bolt. Where Blind Bolts are used for wind load resistance or seismic load resistance in Seismic Design Categories (SDC) A - C, special inspection requirements must comply with Sections 1704.3 and 1705 of the 2018, 2015 and 2012 IBC or Sections 1705, 1706 and 1707 of the 2009 IBC.

5.0 CONDITIONS OF USE

Blind Bolts described in this report comply with, or are suitable alternatives to what is specified in, the code noted in Section 1.0 of this report, subject to the following conditions:

- 5.1 Calculations and details showing that the Blind Bolts are adequate to resist the applied loads must be submitted to the code official for approval. The connected steel base materials and connecting elements also must be adequate to support the applied loads. The calculations and details must be signed and sealed by a registered design professional, when required by the statutes of the jurisdiction in which the project is to be constructed.
- 5.2 Fire-resistive construction: Where not otherwise prohibited in the code, Blind Bolts are permitted for use with fire-resistance-rated construction provided that at least one of the following conditions is fulfilled:
 - The Blind Bolts are used to resist wind or seismic forces in SDC A – C only.
 - Blind Bolts that support a fire-resistance-rated envelope or a fire-resistance-rated membrane, are protected by approved fire-resistance-rated materials, or have been evaluated for resistance to fire exposure in accordance with recognized standards.
 - Blind Bolts are used to support nonstructural elements.
- 5.3 Special inspection must be provided as specified in Section 4.3 of this report.
- 5.4 Use of Blind Bolts in seismic force-resisting structures assigned to Seismic Design Category (SDC) A - C, is intended to be used as a force-controlled component and is not expected to undergo significant inelastic deformation, and the registered design professional shall consider this forced-controlled behavior in the design.
- 5.5 Use of Blind Bolts in applications where the applicable code requires slip-critical installation, is beyond the scope of this report.

6.0 EVIDENCE SUBMITTED

Data in accordance with the ICC-ES Acceptance Criteria for Blind Bolts in Structural Steel Connections (AC437), dated December 2019.

7.0 IDENTIFICATION

- 7.1 The Blind Bolt package is labeled with the product part number, quantity, batch number, an image of the product and ESR-3617. Each package of the Blind Bolts also includes the following information: installation and safety instructions, minimum and maximum fixing ranges (thickness of the steel elements), installation torque and special inspection requirements.
- 7.2 The report holder's contact information is the following:

HENRY VENABLES PRODUCTS, LTD.
THE WOODHOUSE, HOPTON WAFERS
KIDDERMINSTER
WORCESTER DY14 0EE
UNITED KINGDOM
+44 (01299) 272 955
www.blindbolt.co.uk

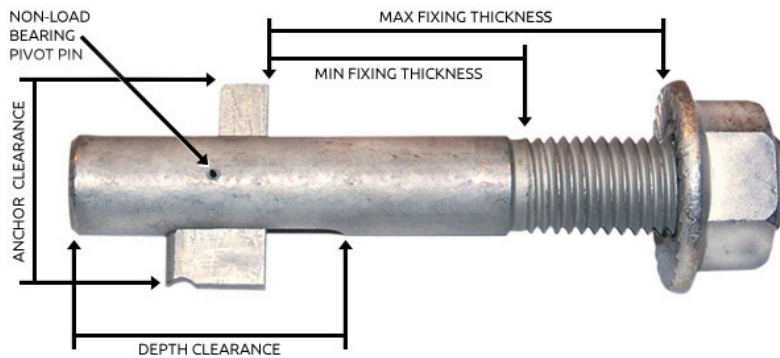
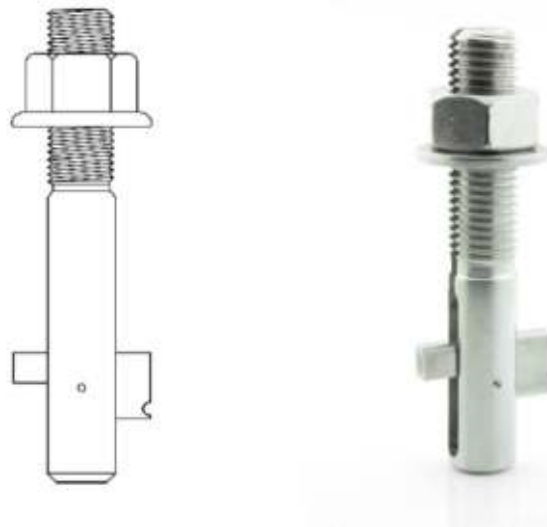

FIGURE 1—TYPICAL BLIND BOLT

TABLE 1—CARBON STEEL BLIND BOLT PRODUCT SPECIFICATIONS

Blind Bolt Size	Hole Diameter (mm)	Fastened Thickness (mm)		Bolt Clearance (mm) ¹	Depth Clearance ² (mm)	Min. Hole Center (mm)
		Min.	Max.			
M8 x 50	9	9	24	19	25	22
M10 x 60	11	10	30	23	30	26
M10 x 95	11	25	65	23	30	26
M10 x 130	11	55	100	23	30	26
M12 x 70	13	12	35	26	35	32
M12 x 120	13	30	85	26	35	32
M12 x 180	13	80	140	26	35	32
M14 x 75	14.5	14	35	32	38	36
M14 x 125	14.5	28	82	32	38	36
M14 x 185	14.5	75	142	32	38	36
M16 x 90	17	13	43	36	43	40
M16 x 130	17	40	75	36	43	40
M16 x 180	17	55	125	36	43	40
M20 x 110	22	21	56	44	56	48

TABLE 1—CARBON STEEL BLIND BOLT PRODUCT SPECIFICATIONS (Continued)

Blind Bolt Size	Hole Diameter (mm)	Fastened Thickness (mm)		Bolt Clearance (mm) ¹	Depth Clearance ² (mm)	Min. Hole Center (mm)
		Min.	Max.			
M20 x 140	22	21	86	44	56	48
M20 x 180	22	80	120	44	56	48
M20 x 250	22	130	185	44	56	48
M24 x 130	26	21	66	53	64	58
M30 x 140	32	27	60	65	72	74

For SI: 1 mm = 0.0394 in.

1. Bolt clearance dimension is the width of the toggle in the open position perpendicular to the bolt axis.
2. Depth clearance dimension is the length from the bottom of the bolt to the top of the toggle slot.

TABLE 2—STAINLESS STEEL BLIND BOLT PRODUCT SPECIFICATIONS

Blind Bolt Size	Hole Diameter (mm)	Fastened Thickness (mm)		Bolt Clearance ¹ (mm)	Depth Clearance ² (mm)	Min. Hole Center (mm)
		Min	Max			
M8 x 50	9	9	24	19	25	22
M10 x 60	11	10	30	23	30	26
M12 x 90	13	12	55	26	35	32
M16 x 100	17	13	53	36	43	40

For SI: 1 mm = 0.0394 in.

1. Bolt clearance dimension is the width of the toggle in the open position perpendicular to the bolt axis.
2. Depth clearance dimension is the length from the bottom of the bolt to the top of the toggle slot.

TABLE 3—CARBON STEEL BLINDBOLT TECHNICAL DATA FOR RESISTING STATIC, WIND AND SEISMIC LOADS (SDC A - C)¹

Blind Bolt Size	Installation Torque (ft-lbf)	LRFD		ASD	
		Tension (lbf)	Shear (lbf)	Tension (lbf)	Shear (lbf)
M8	8	585	1,304	337	809
M10	11	2,136	3,080	1,326	1,933
M12	22	3,395	4,002	2,113	2,495
M14	28	5,103	5,508	3,192	3,440
M16	36	6,385	6,902	4,002	4,316
M20	48	10,206	12,140	6,385	7,576
M24	55	16,951	17,018	10,454	10,633
M30	63	24,774	24,886	15,489	15,557

For SI: 1 ft-lbf = 1.36 N-m; 1 lbf = 4.448 N

- ¹ From tests performed, the following lowest factors were used for the LRFD and ASD calculations:
 Tension: LRFD $\phi = 0.61$, ASD $\Omega = 2.57$
 Shear: LRFD $\phi = 0.56$, ASD $\Omega = 2.73$

TABLE 4—STAINLESS STEEL BLINDBOLT TECHNICAL DATA FOR RESISTING STATIC, WIND AND SEISMIC LOADS (SDC A - C)¹

Blind Bolt Size	Installation Torque (ft-lbf)	LRFD		ASD	
		Tension (lbf)	Shear (lbf)	Tension (lbf)	Shear (lbf)
M8	11	877	1,506	540	1,012
M10	16	2,068	2,563	1,304	1,709
M12	20	3,237	3,574	2,023	2,383
M16	33	6,969	6,969	4,361	4,631

For SI: 1 ft-lbf = 1.36 N-m; 1 lbf = 4.448 N

- ¹ From tests performed, the following lowest factors were used for the LRFD and ASD calculations:
 Tension: LRFD $\phi = 0.60$, ASD $\Omega = 2.57$
 Shear: LRFD $\phi = 0.59$, ASD $\Omega = 2.73$

TABLE 5—BLIND BOLT MINIMUM END DISTANCE, EDGE DISTANCE AND SPACING¹

Blind Bolt Diameter	Minimum End Distance (mm)	Minimum Edge Distance (mm)	Minimum Spacing (mm)
M8	12	12	22
M10	14	14	26
M12	18	18	32
M14	20	20	36
M16	22	22	40
M20	26	26	48
M24	30	30	58
M30	38	38	74

For SI: 1 mm = 0.0394 in.

¹ The tabulated values provide the Blind Bolt minimum end distance, edge distance and spacing. In addition to following the minimum dimensions, registered design professionals must calculate the bearing and tearout strength at bolt holes in accordance with AISC 360 Section J3.10.

BLIND BOLT

Full technical details and distributor information can be found on our website www.blindbolt.co.uk
All dimensions are stated in millimeters unless noted otherwise.

BLIND BOLT
COMPANY

Removal

- To remove a Blind Bolt release the fixing nut but DO NOT remove it.
- Push the Blind Bolt further into the fixing hole and rotate the entire bolt 180°. (See indicator mark diagram for reference.)
- Remove the Blind Bolt once anchor has been allowed.

Diameter & Torque Reference

Bolt Size	Hex Diameter		Recommended Tightening Torque	
	(mm)	(in)	(Nm)	(ft-lb)
M8	8	5/16	15	11
M10	11	7/16	24	18
M12	13	1/2	30	22
M14	15	5/8	34	25
M16	17	5/8	53	39
M20	22	7/8	95	69
M24	26	1	176	129
M30	32	1 1/4	303	222

© Blind Bolt Company T: +44(0)1296 272955 E: enquiries@blindbolt.co.uk

FIGURE 2—INSTALLATION INSTRUCTIONS